

# BUILT-IN COFFEE MACHINE



## ILEM46 X/BV



### THE BEST COFFEE AT HOME!

The ILEM46X is a fully automatic coffee maker, with a steam facility for a cappuccino and various other hot drinks. It allows you to choose the quality of the coffee you want by the automatic grinder presets, QTY of ground coffee & coffee brewing amount for that perfect caffeine hit when you want it!

### CONTROL PANEL

The control panel with touch sensors, include icons of the various functions available which makes it easy to select your desired operation. It will also alert you when cleaning or refilling is required

### COFFEE BREWING

You can choose the type of coffee that want to brew be it short, medium or long and also between different grades of grinding, so to vary the consistency of the coffee and the intensity of the aroma and strength

### COFFEE COMPARTMENT

The container holds 200g of coffee beans, with a single grinding machine, for a consistent quality of each cup of coffee. A warning light on the control panel connected to a sensor in the container will alert you when it needs refilling

### WATER TANK

The built-in water tank will hold 1.8L of water with a scale filter that is positioned at the side of the machine. A sensor connected to the light on the control panel will alert you when you need to top up the water



### Standard Option - Colour



Stainless Steel

Black Glass



# BUILT-IN COFFEE MACHINE



## ILEM46 X/BV

### ILEM46 X/BV COFFEE MACHINE

#### FINISH

- Stainless Steel (X) or black glass (BV) fascia with black interior

#### FEATURES

- Touch-control instrument panel
- A class energy rating
- LED lighting
- Water refill indicator light
- Coffee beans or pre-ground coffee
- Coffee-bean container (200g)
- Connection cable with plug
- x 2 storage drawers

#### FUNCTIONS

- Automatic operation
- 3 auto functions: coffee, steam, hot water
- 5 auto coffee programs: espresso, small cup, medium cup, large cup, mug
- Auto 200ml hot water

#### CAPACITY & INTERIOR

- 1.8L water tank

#### CLEANING

- Indicator that the ground coffee container needs to be emptied
- Automating cleaning cycle
- Rinse function & descaling

#### ACCESSORIES

- Milk container 0,75 L
- drip tray

#### TECHNICAL INFORMATION

- 15 amp electrical connection, plug & lead supplied
- Size: 595W x 458H x 396 D +21mm fascia
- MAX Absorbed power(W) 1350W

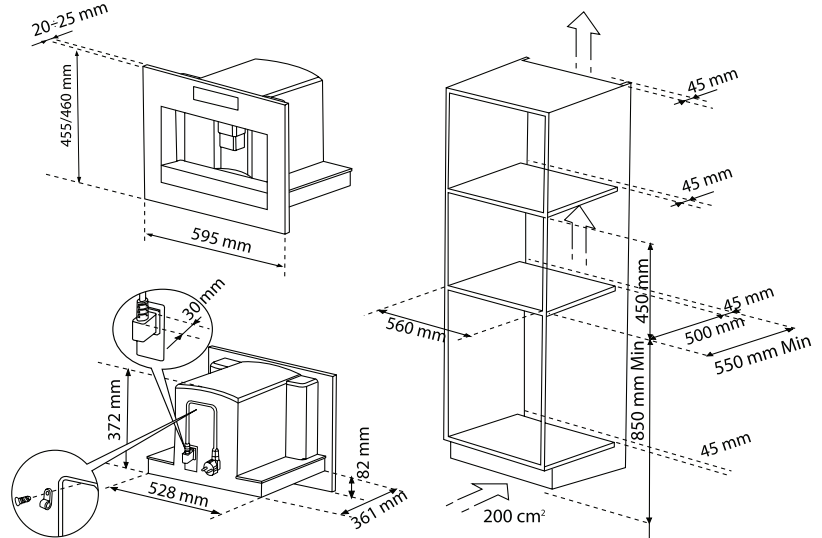

#### Microwave

EAN code: 9341584122827 (ILEM46X)

EAN code: 9341584109170 (ILEM46BV)

Product Size: 595W x 455H x 361D + 20-25mm fascia

Annual energy consumption kWh: 45

NB: drawings are not to scale — they are to be used as a guide only

### FOLLOW US:



/ilve\_appliances/



/ILVEappliances



/ILVE\_appliances



/ILVEappliances

Page 2/2  
02112021

Australia National Telephone Number 1300 MYILVE (694 583) New Zealand Telephone Number 0508 458 369  
ILVE showrooms are open daily from 9am-5pm and Saturdays 10am-4pm

ilve.com.au

#### NSW & ACT (Head Office)

48-50 Moore Street  
Leichhardt  
F 02 8569 4699

#### QLD

1/42 Cavendish Road  
Coorparoo  
F 07 3397 0850

#### WA & NT

Unit 10/55 Howe Street  
Osborne Park  
F 08 9201 9188

#### New Zealand

PO Box 11.160  
Sockburn Christchurch  
F 03 344 5906

DISCLAIMER  
Eurolinx PTY LTD, trading as ILVE Appliances, is continually seeking ways to improve the design specifications, aesthetics and production techniques of its products. As a result alterations to our products and designs take place continually. Whilst every effort is made to produce information and literature that is up to date, this brochure should not be regarded as an infallible guide to the current specifications, nor does it constitute an offer for the sale of any particular product. Product dimensions indicated in our literature is indicative only. Actual product only should be used to define dimension cutouts. Distributors, and retailers are not agents of ILVE Appliances and are not authorized to bind ILVE Appliances by any express or implied undertaking or representation.